



Relay module for
smoke alarm device
Dual
2340 00

GIRA

Gira
Giersiepen GmbH & Co KG
Electrical installation systems
P.O. Box 1220
42461 Radevormwald
Phone +49 (0) 2195 602 - 0
Fax +49 (0) 2195 602 - 191

info@gira.de
www.gira.de

282341001 35/14



Smoke alarm device Dual Q

Please see the installation and operating instructions of the smoke alarm device Dual Q for all the functions of the smoke alarm device Dual Q (e.g. installation, signals, function test, etc.).

Device description

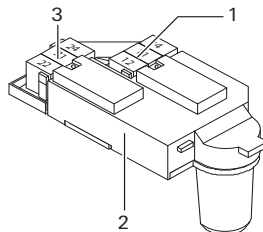

- 1 Alarm relay
- 2 Relay module
- 3 Fault relay

Function of the alarm relay

The alarm relay forwards smoke or temperature alarms to the connected device. The alarm relay responds as soon as one of the specified alarms is triggered in the smoke alarm device.

Behaviour when wired networking is used for the smoke alarm device

If wired networking is used for the smoke alarm device, the alarm signal of all connected smoke alarm devices is forwarded via the alarm relay.

Terminal designation

The zero-voltage terminals of the alarm relay are designated as follows:

- 11: Centre contact
- 12: NC contact
- 14: NO contact

Switching condition in normal operation

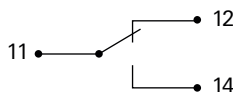

Switching condition for alarm messages

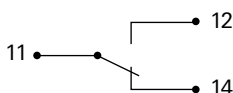

Function of the fault relay

The fault relay forwards the messages "Fault/soiling" and "Weak battery" to the connected device. The fault relay responds as soon as one of the specified messages is triggered in the smoke alarm device.

Behaviour when wired networking is used for the smoke alarm devices

If wired networking is used, only the fault of the smoke alarm device in which the relay module is installed is forwarded via the fault relay. If all smoke alarm devices should be monitored for faults, a relay module must be inserted into each smoke alarm device.

Terminal designations

The zero-voltage terminals of the fault relay are designated as follows:

- 21: Centre contact
- 22: NC contact
- 24: NO contact

Switching condition in normal operation

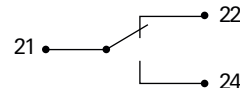

Switching condition for fault messages

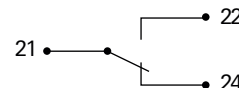

Installing the module



For use with a 230 V base

For safety reasons, the connection cable must be isolated down to the terminals of the relay module.

1. Switch the mains voltage off.
2. Strip the connection cable of the relay module. For easier installation and removal of the relay module, sufficient connection cable length (approx. 10 cm) must be observed.
3. Connect connection cable (J-Y(ST)Y 2x2x0.6 or YR 4x0.8) to the terminals of the relay module.
4. Insert the module with the connection pins into the module interface (1) of the smoke alarm device until the module engages.

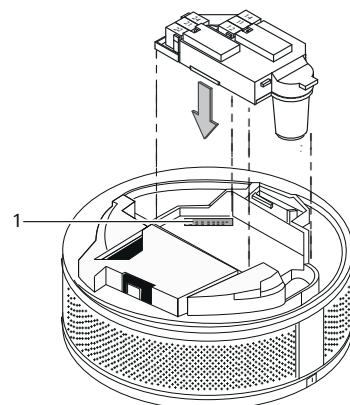

5. Lock the smoke alarm device onto the mounting plate or the 230 V base.
6. Switch mains voltage back on.
7. Perform function test.

General safety instructions

Installation and mounting of electrical devices may only be carried out by qualified electricians.

Serious injury (e.g. caused by an electric shock), fire, or material damage are possible in case of improper mounting.



Configuration and installation may only be performed by an expert

As per DIN EN 14676, configuration, installation and maintenance of the smoke alarm device may only be performed by a qualified expert. For this purpose, Gira offers the "Certified expert for smoke alarm devices in accordance with DIN EN 14676" online course, complete with certificate. More detailed information can be found under "akademie.gira.de".

Read these instructions thoroughly and observe them. These instructions are part of the product and must remain with the end customer.

Product features

The relay module for the smoke alarm device Dual enables external alarm devices (e.g. a horn or warning light) to be connected to the Gira smoke alarm device Dual Q.

The relay module is downward compatible, which means it can also be used for the smoke alarm device Dual/VdS.

Alarm and fault messages can still be switched on a TeleCoppler or alarm control unit or forwarded to the KNX bus via a push button interface. The relay module features two relays (alarm relay and fault relay) which switch for different states.



Connecting inductive loads

When an inductive load is connected, a freewheeling diode must be included in the circuit.

Function test

After the relay module has been installed, a function test must be performed to guarantee the functionality of the relay module.

The function test is passed as soon as the alarm relay on contact 14 switches and the receiver connected to it signals the alarm.

Technical data

Relay contact, alarm

Type: 2-way switch,
zero-voltage

Switching voltage: max. AC/DC 30 V

Switching current: max. AC/DC 1 A

Relay contact, fault

Type: 2-way switch,
zero-voltage

Switching voltage: max. AC/DC 30 V

Switching current: max. AC/DC 1 A

Connection diameter: 0.6 to 0.8 mm

Warranty

The warranty is provided in accordance with statutory requirements via the specialist trade.

Please submit or send faulty devices postage paid together with an error description to your responsible salesperson (specialist trade/installation company/specialist electrical trade).

They will forward the devices to the Gira Service Center